



JUNCTION BOX INSTALLATION KIT FOR THUNDERSTONE TARP KIT AND EZ-FLOW TRAP OR THUNDER ELECTRIC TRAP KITS

ITEM NO.	JCT BOX INSTAL - 101738	QTY.	DESCRIPTION
1	031-51026	2	RING TERMINAL 4ga x 1/4" STUD
2	031-51117	1	RING TERMINAL 6ga x 3/8" STUD
3	034-04709	1	HEAT SHRIK TUBE 1/2"
4	034-58993	2	HEAT SHRIK TUBE 1/2" RED
5	035-52548	1	GREASE CORROSION PROTECTIVE COATING ELECTRICAL
6	101007	4	SCREW #14-24 X 3/4" SS DRILL TAP

USE THIS WHEN INSTALLING THUNDER ELECTRIC TARPS WITH THE EZ-FLOW HYDRAULIC DOORS OR THE THUNDER ELECTRIC TRAPS. THE BOX HAS A 50 AMP CIRCUIT INSTALLED TO PROTECT THE TARP SYSTEM FROM POWER SURGES. WIRE AS SHOWN TO MAKE SURE BOTH SYSTEMS OPERATE.

DISCONNECT ALL POWER TO THE TRAILER BY UNPLUGGING THE SYSTEM FROM THE TRACTOR BEFORE WORKING ON TRAILER.

JUNCTION BOX MOUNTING INSTRUCTIONS:

BEFORE INSTALLING MAKE SURE YOU ARE CLOSE ENOUGH TO THE NOSE PLUG FOR ALL THE WIRES TO REACH INTO THE BOX.

- CLEAN POST WITH WIRE BRUSH WHERE PLATE WILL BE INSTALLED. (SURFACE MUST BE CLEAN TO MAKE GOOD CONTACT FOR THE GROUND WIRE.)
- USE THE FOUR #4-24 X 3/4" SCREWS TO ATTACH THE MOUNTING PLATE TO THE Z-POSTS.

JUNCTION BOX WIRING INSTRUCTIONS (EXISTING TARP SYSTEM):

USE DIELECTRIC GREASE AT ALL ELECTRICAL CONNECTIONS TO PROTECT FROM CORROSION AND INSURE GOOD CONTACT.

- REMOVE THE POSITIVE AND NEGATIVE WIRE FROM THE NOSE PLUG AND RUN THEM THROUGH THE STRAIN RELIEFS AS SHOWN, THEN SNUG THE STRAIN RELIEF OUTER NUT TO HOLD IN PLACE.
- RUN THE POSITIVE WIRE FOR THE TRAP SYSTEM THROUGH A STRAIN RELIEF AS SHOWN AND SNUG THE OUTER NUT TO HOLD IN PLACE.
- RUN THE TWO PRE-INSTALLED 18" LONG WIRES THROUGH THE NOSE PLUG BOOT.
- PUT THE POSITIVE (RED) WIRE INTO THE TOP HOLE AND THE GROUND WIRE (BLACK) INTO THE BOTTOM HOLE OF THE NOSE PLUG AND TIGHTEN.
- INSTALL A 1/4" LUG ON THE POSITIVE POWER WIRE FOR THE TRAP SYSTEM, A 1/4" LUG ON THE POSITIVE WIRE FROM THE TARP SYSTEM.
- INSTALL A 3/8" LUG ON THE GROUND WIRES FOR THE TARP SYSTEM.
- PUT 1" OF 1/2" HEAT SHRINK TUBE OVER THE THREE LUGS TO PROTECT FROM ACCIDENTAL CONTACT AND SHORTING OUT THEN HEAT THE TUBING TO SEAL.
- REMOVE THE #10 K-LOCK NUT FROM THE BAT(GOLD) AND AUX(SILVER) POST OF THE 50 AMP CIRCUIT BREAKER.
- INSTALL THE POSITIVE POWER WIRE FROM THE TRAP SYSTEMS TO THE BAT (GOLD) POST OF THE CIRCUIT BREAKER ON TOP OF THE PRE INSTALLED POWER WIRE.
- CONNECT THE POSITIVE WIRE FROM THE TARP SYSTEM TO THE SILVER (AUX) POST OF THE CIRCUIT BREAKER.
- REPLACE THE #10 K-LOCK NUTS AND MAKE SURE THE STAR WASHER IS FACING THE RING TERMINAL, THEN TIGHTEN THE NUTS.
- REMOVE THE 3/8" FLANGE NUT FROM THE GROUND BOLT.
- CONNECT THE GROUND WIRE FROM THE TARP SYSTEM ON TOP OF THE PRE INSTALLED GROUND WIRE INSTALLED ON THE GROUNDING BOLT.
- REPLACE THE 3/8" FLANGE NUT AND TIGHTEN.
- TIGHTEN ALL OF THE OUTER STRAIN RELIEF NUTS AND PULL GENTLY ON THE WIRES TO MAKE SURE THEY ARE SECURE.
- PLUG IN THE TRAILER AND MAKE SURE ALL THE SYSTEMS WILL POWER UP.
- PUT COVER ON THE BOX.

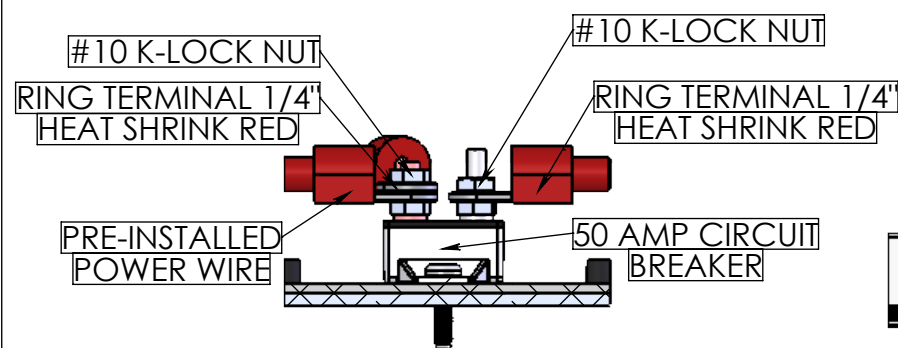
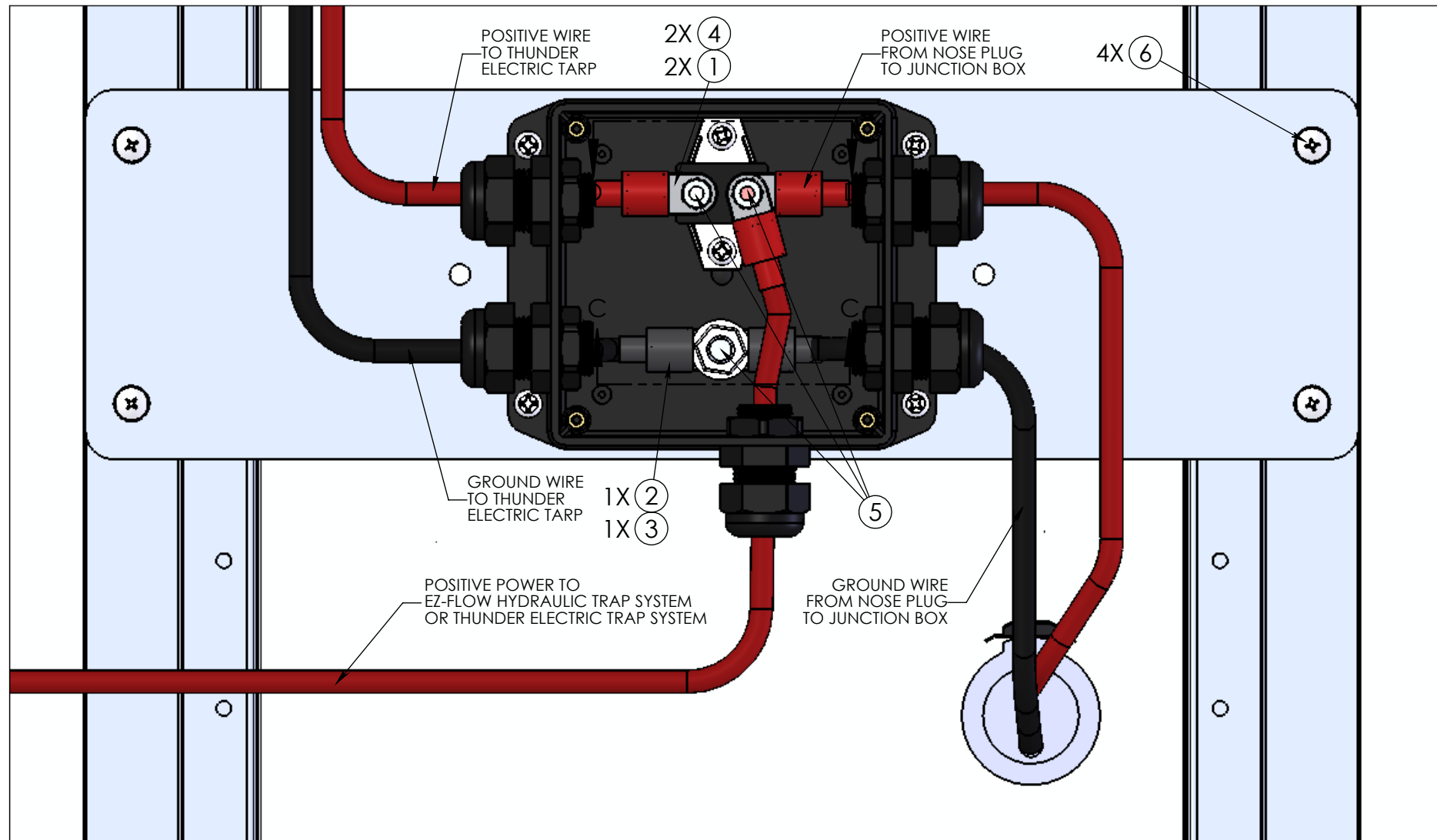

SECTION D-D
SCALE 1 : 2

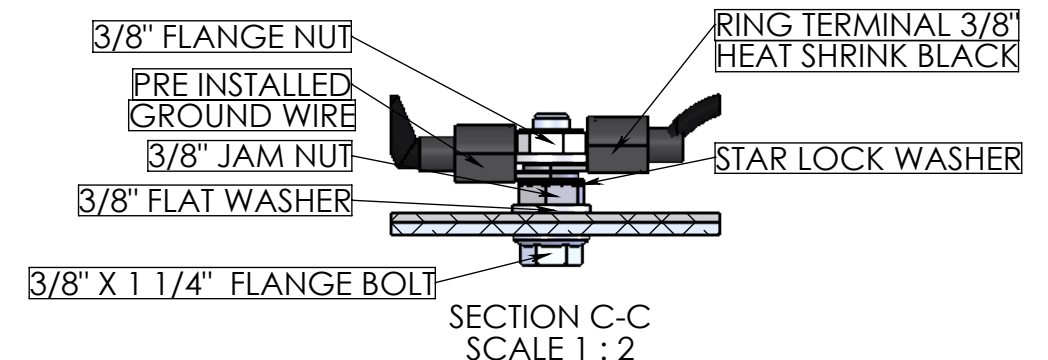
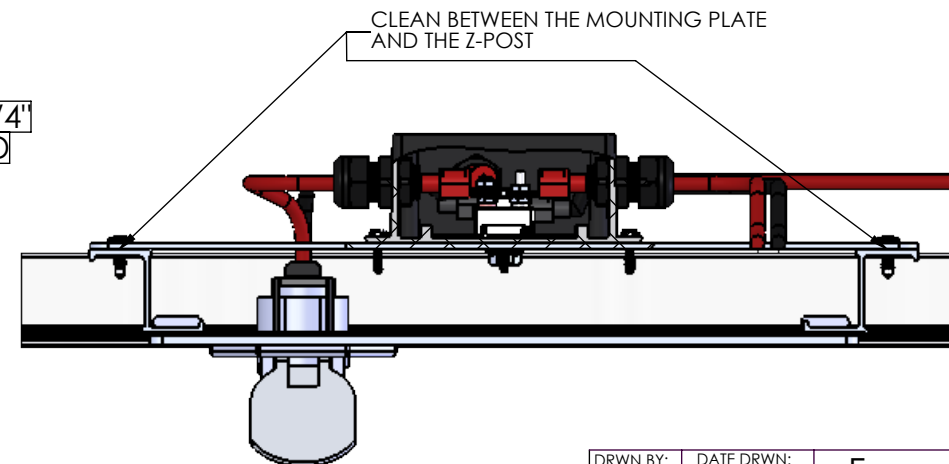

SECTION C-C
SCALE 1 : 2

DRWN BY: MGW
DATE DRWN: 11/8/2016

For questions contact customer service @ 402-435-4249

DWG. NO. JCT BOX INSTAL - 101738
REV:

ORIGINAL