

EQUIPMENT TRAILERS LOADING WINCH KIT INSTALLATION MANUAL

Congratulations on the purchase of your new Timpte Motorsports trailer accessory. Here at Timpte, Inc. we take pride in the quality of our trailers and hope your experience with our company meets or exceeds all of your expectations. If at any time you experience issues, please do not hesitate to contact your authorized dealer for service or warranty.



This installation manual contains information and instructions for the safe installation of your new accessory. Make sure to read this manual thoroughly prior to installing the accessory on the trailer. Timpte, Inc. Advises users to follow all safety precautions and instructions.

WARNING



Disconnect all electrical systems from the trailer before beginning installation. Failure to do so may cause damage to the trailer or tow vehicles electrical systems.



Beware of sharp edges! Actions performed during the installation of this kit will create sharp edges that can cause severe personal injury. Personal protective equipment is required to avoid injury.

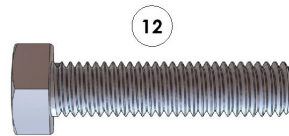
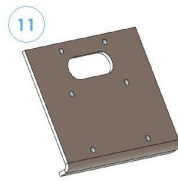

PARTS LIST:

****ENSURE ALL PARTS ARE ACCOUNTED FOR BEFORE PROCEEDING****

1. Winch, 4500lb
2. Control solenoid
3. Control button
4. Remote receiver
5. "Y" splitter, control cables
6. Long electrical wires (not used for installation)
7. Short electrical wires
8. Remote control transmitter 2pcs
9. Nylon ties
10. L-Track stud 2pcs
11. Mounting plate
12. Bolt, M8x1.25 35mm long 4pcs
13. Grommet 3pcs
14. Quick connect, long
15. Quick connect, short

Tool List

10mm combination wrench or socket 2pcs
13mm combination wrench or socket 2pcs
17mm combination wrench or socket
Ratchet for sockets
5/32" Hex driver
1/4" drill bit (.250")
7/8" drill bit (.875")
Hand held drill
Tape Measure

Step 1. Attach the fairlead to the black mounting plate. See figure 1.

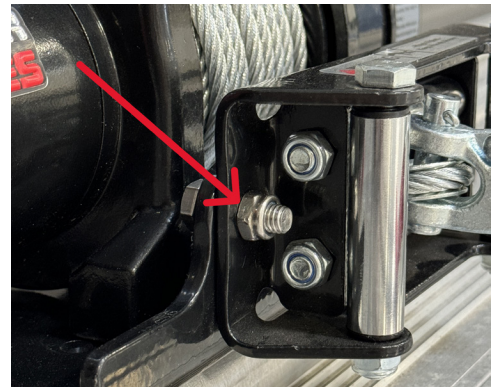

Figure 1. Fairlead mount

Step 2. Attach both mounting plates to the winch. Use the 8mm x 35mm hex head fasteners. See figure 2.

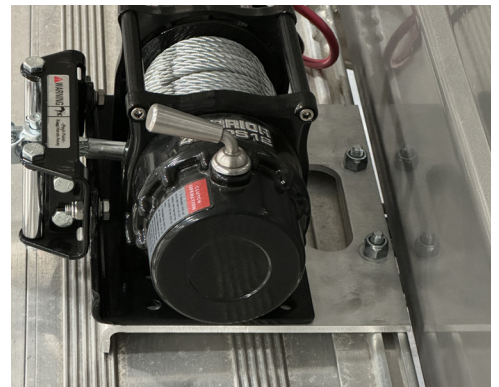

Figure 2. Mounting plates orientation

Step 3. Feed the synthetic rope through the fairlead and then attach the clevis hook and hand strap to the end. See figure 3.

Note: the winch pictured shows a steel cable, not the synthetic rope that will ship with the kits.



Figure 3. Hook attachment

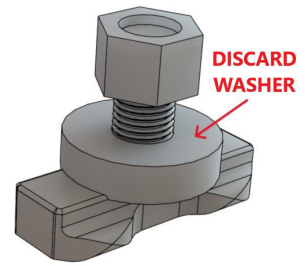

Figure 4. L-Track stud

Step 4. Determine where the winch will be mounted on the front rail. Insert 2 L-Track studs. Discard the included washers. Place the winch assembly over the L-Track studs and then secure it with the provided nuts. See figures 4 and 5.

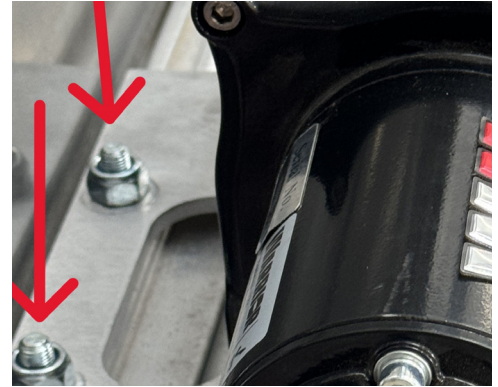

Figure 5. Winch L-Track studs

Step 5. Open trailer tool box and remove 4 fasteners securing the battery compartment cover. Remove the cover. See figure 6.



Step 5A. Disconnect the battery cables before proceeding. **USE CAUTION.** A short circuit condition with the battery can cause flying sparks and possibly cause damage to the electrical system.



Figure 6. Battery compartment cover fastener locations.

Step 6. Locate an appropriate location to mount the solenoid to the inside divider of the toolbox. Mark hole locations and drill holes with a 1/4" (.250") bit. Install fasteners and secure solenoid to divider, on the battery side. Also feed the silver metal connector through the grommet, towards the quick connect wires. See figure 7.

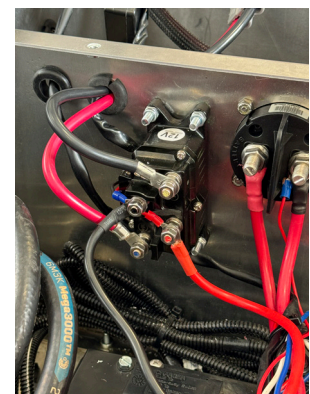

Figure 7. Solenoid location

Step 7. Connect the short red and black wires from the kit to the red and black posts on the winch solenoid. Once secure, connect the loose ends to the red and black studs of the lift/lower solenoid on the floor of the toolbox. **DO NOT** bypass the master switch by connecting directly to the battery terminals. See figure 8.



Figure 8. Lift solenoid connections



Step 8. Drill a 7/8" (.875") hole through the divider near the winch solenoid. Be careful, the hole will have **SHARP EDGES**. Next place a grommet in hole. See figure 9.

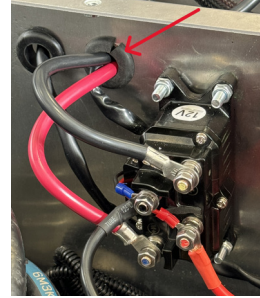

Figure 9. Hole with grommet and wires

Step 9. Insert the short section of the quick connect power wires through the grommet in order to connect the ring terminals to the winch solenoid. Connect the red wire to the blue post and the black wire to the yellow post. See figure 10.



Figure 10. Solenoid connections



Step 10. Drill another 7/8" (.875") hole through the back side of the toolbox. Be careful, the hole will have **SHARP EDGES**. Next place a grommet in hole. See figure 11. Also see figure 15 on last page.

Step 10A. If trailer has a rock guard installed, another hole must be drilled through it, in the same location as the hole in the back side of the toolbox. Drill hole then install grommet. See figure 16 on last page

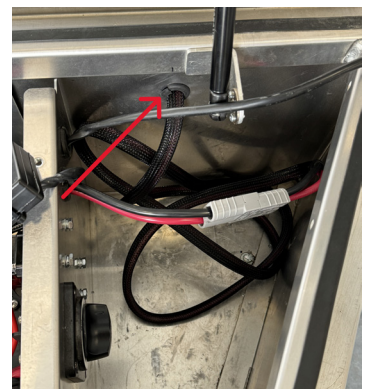

Figure 11. Hole through back wall

Step 11. Feed wires from the long section of the quick connect power wires through the grommets and prepare to attach to the winch. Slide the red boot onto the red wire and the black boot onto the black wire. Attach the red wire on the post marked with (+) sign. This post also is marked with a red/orange washer. Attach the black wire on the other post which is marked with the blue washer. Connect the two sections of power wire with the quick connect. See figures 12 and 13.

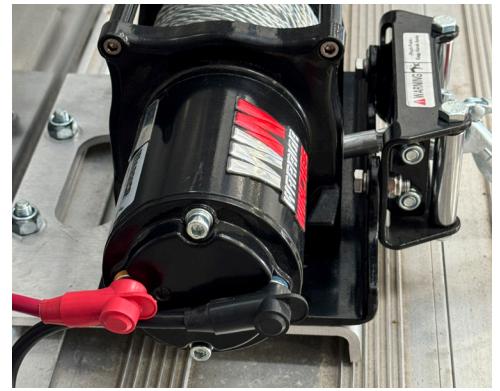

Figure 12. Winch power connections



Figure 13. Quick connection

Step 12. Connect the “Y” splitter to the round metal connector that leads back to the solenoid. Then connect the control button and the remote control receiver to the “Y” splitter cable. Excess wires can now be gathered and secured together with the supplied nylon ties. See figure 14.



Figure 14. “Y” splitter connections

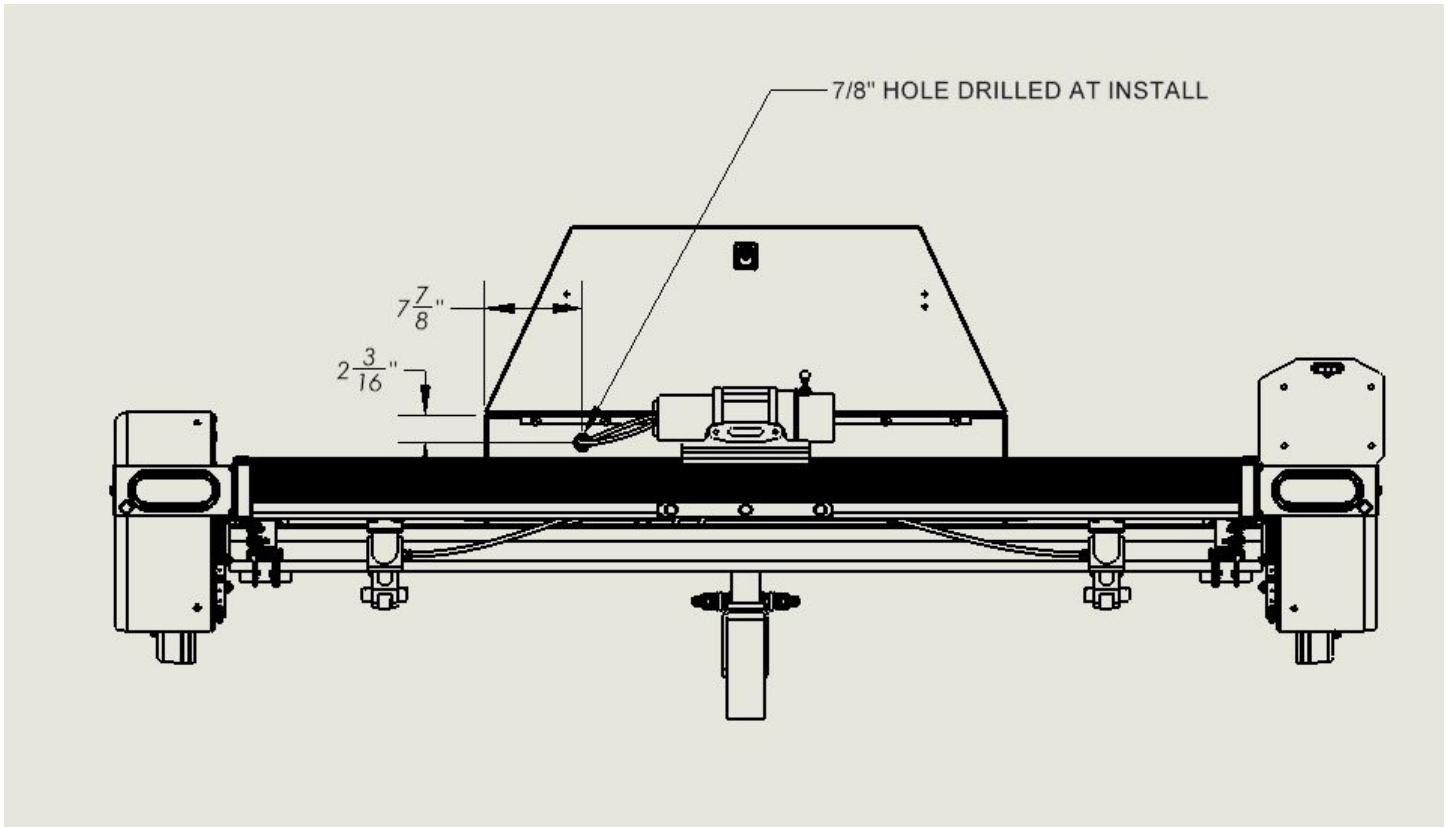

Figure 15. Location to drill hole in toolbox

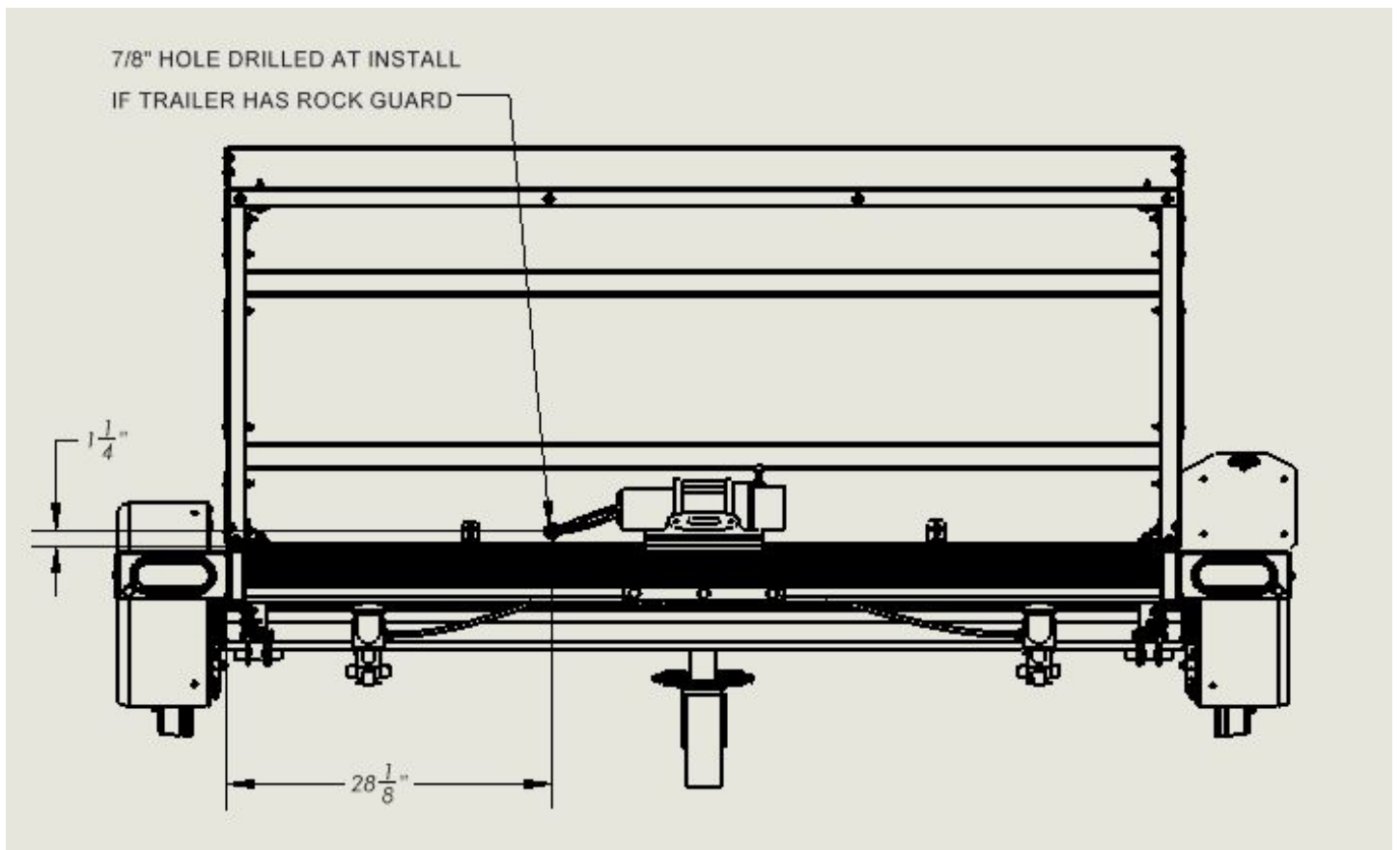

Figure 16. Location to drill hole in rock guard if equipped